

CE

**CIVIK**

IP1953EN - rev. 2012-06-01



**Assembly, Installation and  
Maintenance handbook  
for internal sliding door.**  
(Original instructions)



ISO 9001  
Cert. n° 0957

**DITEC S.p.A.**

Via Mons. Banfi, 3 - 21042 Caronno Pertusella (VA) - ITALY

Tel. +39 02 963911 - Fax +39 02 9650314

[www.ditec.it](http://www.ditec.it) - [ditec@ditecva.com](mailto:ditec@ditecva.com)

## INDEX

Subject	Page
1. General safety precautions	3
2. Declaration of incorporation of partly completed machinery	4
2.1 Machinery Directive	4
3. Technical specifications	5
3.1 Operating instructions	5
4. Standard installation	6
5. Assembling	7
5.1 Assembling procedure	7
5.2 Belt assembling procedure	11
6. Installation	12
6.1 Housing fastening	12
6.2 Preparation of wood door wing	13
6.3 Preparation of glass door wing	14
6.4 Door wing adjustment	15
6.5 Belt adjustment	15
6.6 Floor guide installation	15
6.7 Fastening door wing locking device CIVIKLA	16
6.8 Fastening of the radio receiver OCL	16
6.9 Installation of functions selector switch	16
7. Installation on disappearing doors	17
8. Glass door wing	20
9. Electrical connections	21
9.1 Commands	21
9.2 Output and accessories	21
9.3 Adjustment	22
10. Start-up	22
11. Ordinary maintenance program	22
12. User instructions	23
12.1 General safety precautions	23
12.2 Manual release instruction	23

### All right reserved

All data and specifications have been drawn up and checked with the greatest care. The manufacturer cannot however take any responsibility for eventual errors, omissions or incomplete data due to technical or illustrative purposes.

## 1. GENERAL SAFETY PRECAUTIONS



This installation manual is intended for professionally competent personnel only.

Installation, electrical connections and adjustments must be performed in accordance with Good Working Methods and in compliance with applicable regulations.

Before installing the product, carefully read the instructions.

Bad installation could be hazardous.

The packaging materials (plastic, polystyrene, etc.) should not be discarded in the environment or left within reach of children, as these are a potential source of hazard.

Before installing the product, make sure it is in perfect condition.

Do not install the product in an explosive environment and atmosphere: gas or inflammable fumes are a serious hazard risk.

Before installing the motors, make all structural changes relating to safety clearances and protection or segregation of all areas where there is risk of being crushed, cut or dragged, and danger areas in general.

Make sure the existing structure is up to standard in terms of strength and stability.

The motor manufacturer is not responsible for failure to use Good Working Methods in building the frames to be motorized or for any deformation occurring during use.

The safety devices (photocells, safety edges, emergency stops, etc.) must be installed taking into account: applicable laws and directives, Good Working Methods, installation premises, system operating logic and the forces developed by the motorized door.

The safety devices must protect any areas where the risk exists of being crushed, cut or dragged, or where there are any other risks generated by the motorized door.

Apply hazard area notices required by applicable regulations.

Each installation must clearly show the identification details of the motorized door.



Before making power connections, make sure the plate details correspond to those of the power mains.

Fit an omnipolar disconnection switch with a contact opening gap of at least 3 mm.

Make sure an adequate residual current circuit breaker and overcurrent cutout are fitted upstream of the electrical system.

When necessary, connect the motorized door to a reliable earth system made in accordance with applicable safety regulations.

During installation, maintenance and repair, interrupt the power supply before opening the lid to access the electrical parts.



To handle electronic parts, wear earthed antistatic conductive bracelets.

The motor manufacturer declines all responsibility in the event of component parts being fitted that are not compatible with the safe and correct operation.

For repairs or replacements of products only original spare parts must be used.

The installer shall provide all information relating to automatic, manual and emergency operation of the motorized door, and provide the user with operating instructions.

## 2. DECLARATION OF INCORPORATION OF PARTLY COMPLETED MACHINERY

(Directive 2006/42/EC, Annex II-B)

The manufacturer DITEC S.p.A. with headquarters in Via Mons. Banfi, 3 - 21042 Caronno Pertusella (VA) - ITALY declares that the automation system for CIVIK sliding doors:

- has been constructed to be installed on a manual door to construct a machine pursuant to the Directive 2006/42/EC. The manufacturer of the motorized door shall declare conformity pursuant to the Directive 2006/42/EC (annex II-A), prior to the machine being put into service;
- conforms to applicable essential safety requirements indicated in annex I, chapter 1 of the Directive 2006/42/EC;
- conforms to the Low Voltage Directive 2006/95/EC;
- conforms to the Electromagnetic Compatibility Directive 2004/108/EC;
- technical documentation conforms to Annex VII-B to the Directive 2006/42/EC;
- technical documentation is managed by Renato Calza with offices in Via Mons. Banfi, 3 - 21042 Caronno Pertusella (VA) - ITALY;
- a copy of technical documentation will be provided to national competent authorities, following a suitably justified request.

Caronno Pertusella, 29-06-2010

Silvano Angaroni  
(Managing Director)



### 2.1 Machinery Directive

Pursuant to Machinery Directive (2006/42/EC) the installer who motorizes a door or gate has the same obligations as the manufacturer of machinery and as such must:

- prepare the technical file which must contain the documents indicated in Annex V of the Machinery Directive; (The technical file must be kept and placed at the disposal of competent national authorities for at least ten years from the date of manufacture of the motorized door);
- draw up the EC Declaration of Conformity in accordance with Annex II-A of the Machinery Directive and deliver it to the customer;
- affix the EC marking on the motorized door in accordance with point 1.7.3 of Annex I of the Machinery Directive.

### 3. TECHNICAL DETAILS

	CIVIK 1 WING	CIVIKJ 1 WING	CIVIK 2 WINGS	CIVIKJ 2 WINGS
Power supply	230 V~ / 50-60 Hz	120 V~ / 60 Hz	230 V~ / 50-60 Hz	120 V~ / 60 Hz
Absorption	0,2 A	0,4 A	0,2 A	0,4 A
Accessories power supply	24 V= / 0,3 A	24 V= / 0,3 A	24 V= / 0,3 A	24 V= / 0,3 A
Thrust	30 N	30 N	30 N	30 N
Opening speed	0,4 m/s	0,4 m/s	0,8 m/s	0,8 m/s
Closing speed	0,2 m/s	0,2 m/s	0,4 m/s	0,4 m/s
Intermittence	S2=20 min S3=30%	S2=20 min S3=30%	S2=20 min S3=30%	S2=20 min S3=30%
Max door weight	60 kg	60 kg	80 kg	80 kg
Temperature	-20° C / +55° C	-20° C / +55° C	-20° C / +55° C	-20° C / +55° C
Degree of protection	IP20	IP20	IP20	IP20

#### 3.1 Operating instructions

**Service class: 4** (minimum 10÷5 years of working life with 100÷200 cycles per day).

**Applications: INTENSE** (for apartment block, commercial and healthcare entrances with intense pedestrian use).

- Performance characteristics are to be understood as referring to the recommended weight (approx. 2/3 of maximum permissible weight). When used with the maximum permissible weight a reduction in the above mentioned performance can be expected.
- Service class, running times, and the number of consecutive cycles are to be taken as merely indicative Having been statistically determined under average operating conditions, and are therefore not necessarily applicable to specific conditions of use.
- Each automatic entrance has variable elements such as: friction, balancing and environmental factors, all of which may substantially alter the performance characteristics of the automatic entrance or curtail its working life or parts thereof (including the automatic devices themselves). The installer should adopt suitable safety conditions for each particular installation.



*NOTE: the given operating and performance features can only be guaranteed with the use of DITEC accessories and safety devices.*

## 4. STANDARD INSTALLATION

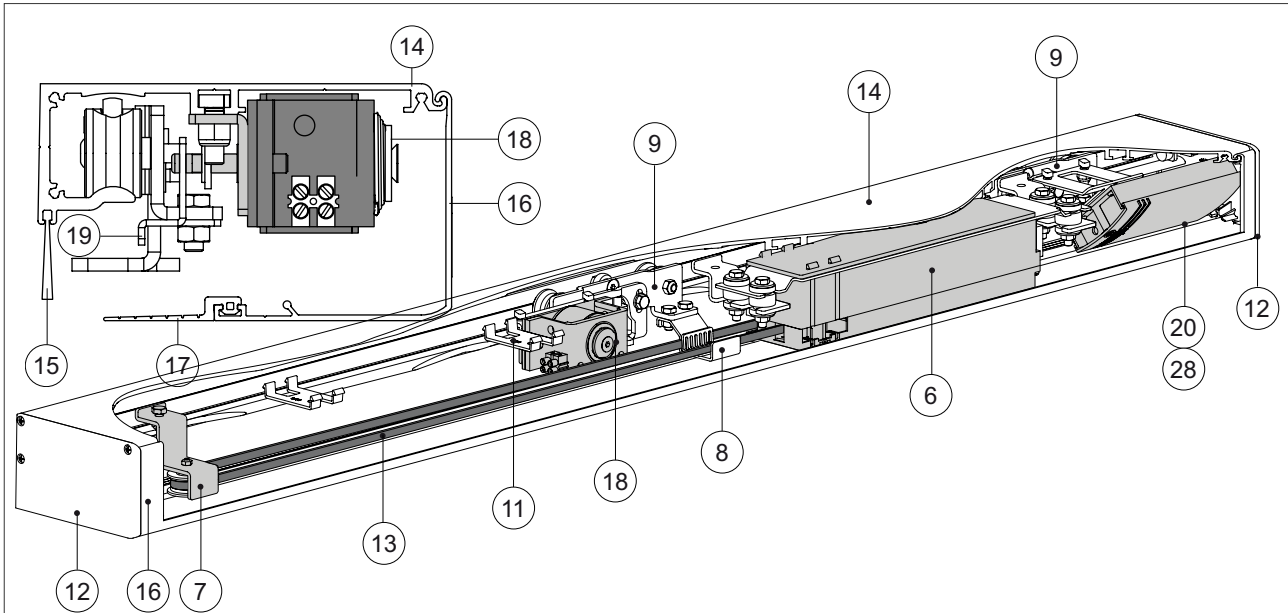
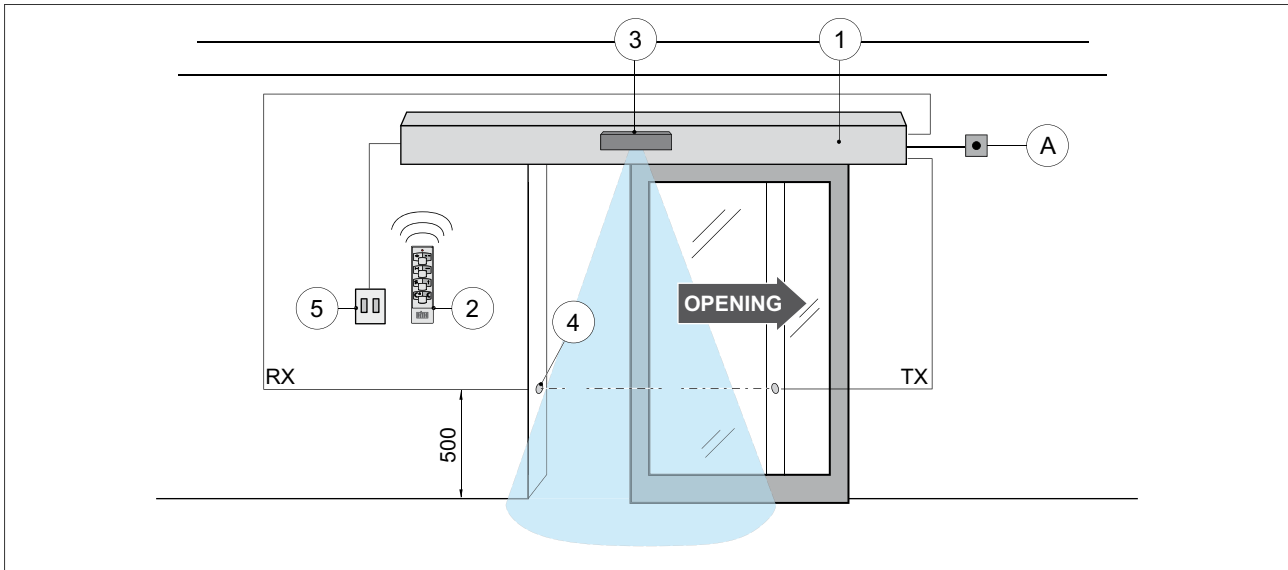

REF.	CODE	DESCRIPTION
A		Power supply plug
1	DOITCVK16 DOITCVK22 DOITCVK33	Operator
2	COMGTC	Wireless functions selector switch
3	PASS24	Opening sensor
4	CELPR	Photocells
5		Push-button
6		Control and drive unit
7		Belt transmission unit
8		Belt attachment bracket
9	KCIVIK1	Carrier unit
10		Rabbed lock
11		Wire bracket
12		Housing heads
13	KXL037K KXL037A	Belt 20 m
14	V3760N33 V3760N66	Housing
15	VSP25V25	Seal brush 2,5 m

REF.	CODE	DESCRIPTION
16	V3759N33 V3759N66 V3759G33 V3759G66	Carter
17	RGR3511	Gasket 40 m
18		Lock
19	CIVIKLA	Lock hook-up bracket
20	OCL	Radio receiver
21	CIVIKAL	Wood door attachment
22	CIVIKAC	Glass door attachment
23	0KP515AB	Sliding guide (10 piece)
24	0KP369	Sliding guide for glass wing (10 piece)
25	K1356N30 K1356N60 K1356G30 K1356G60	Glass wing profile
27	KCIVIKGCL	Second door unit
28	COMGCR	Wireless functions selector switch receiver

## 5. ASSEMBLING

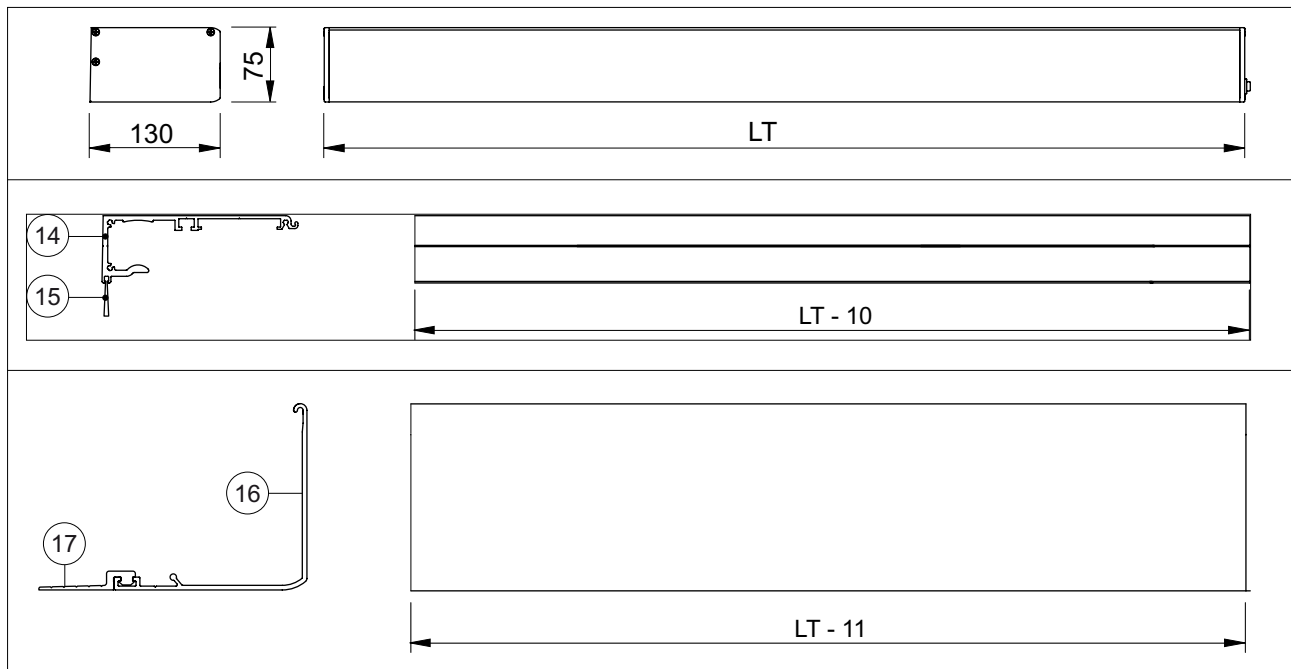

### 5.1 Assembling procedure

The supply modes for the CIVIK automations are as follows:

1. kit of components to be assembled;
2. automations assembled on a door wing in three different lengths.

To assemble the components kits, to reduce the standard LT dimensions, or to carry out an automation for two door wings, proceed as follows.

- Cut the box and the casing as indicated in figure.

*NOTE: remove any cut residues from the aluminium, and clean the carriage slide guides in particular.*

- Assemble the necessary components as follows:

CIVIK 2 door wings, see page 8;

CIVIK 1 door wing with opening to the right, see page 9;

CIVIK 1 door wing with opening to the left, see page 10.

## CIVIK 2

CODE	LT PL + 2LM + 20	LM	PL	A	B	C	D
DOITCVK16 + KCIVIKGCL	1650	(PL + 2S) / 2	LT - 2LM - 20	50	270	550	80
DOITCVK22 + KCIVIKGCL	2200			150	400	700	80
DOITCVK33 + KCIVIKGCL	3300			400	650	1000	80

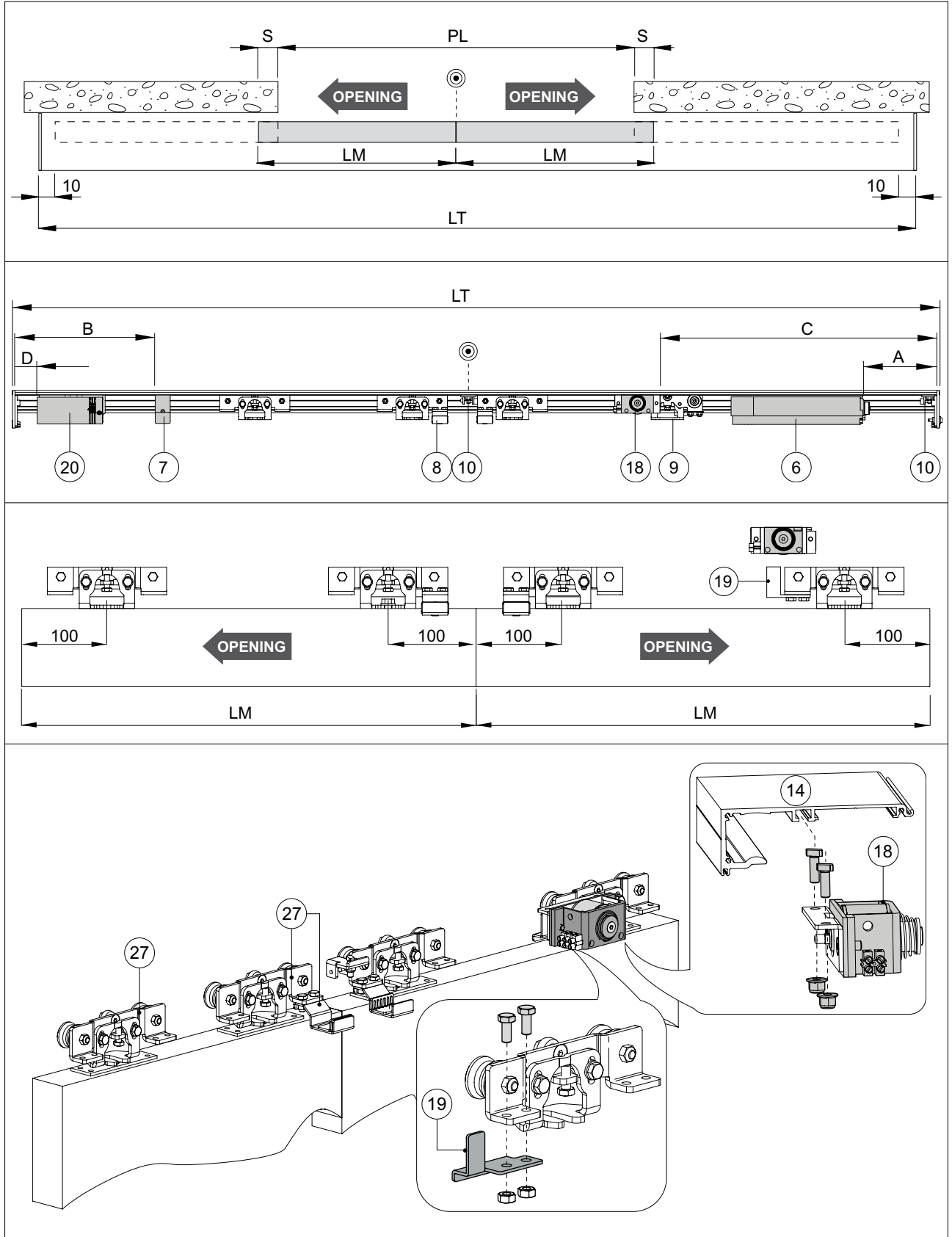



# CIVIK 1 DX

CODE	LT PL + LM + 20 + S	LM	PL	A	B	C	D
DOITCVK16	1650	PL + 2S	LT - LM - 20 - S	250	70	600	80
DOITCVK22	2200			500	70	850	350
DOITCVK33	3300			1000	70	1350	900

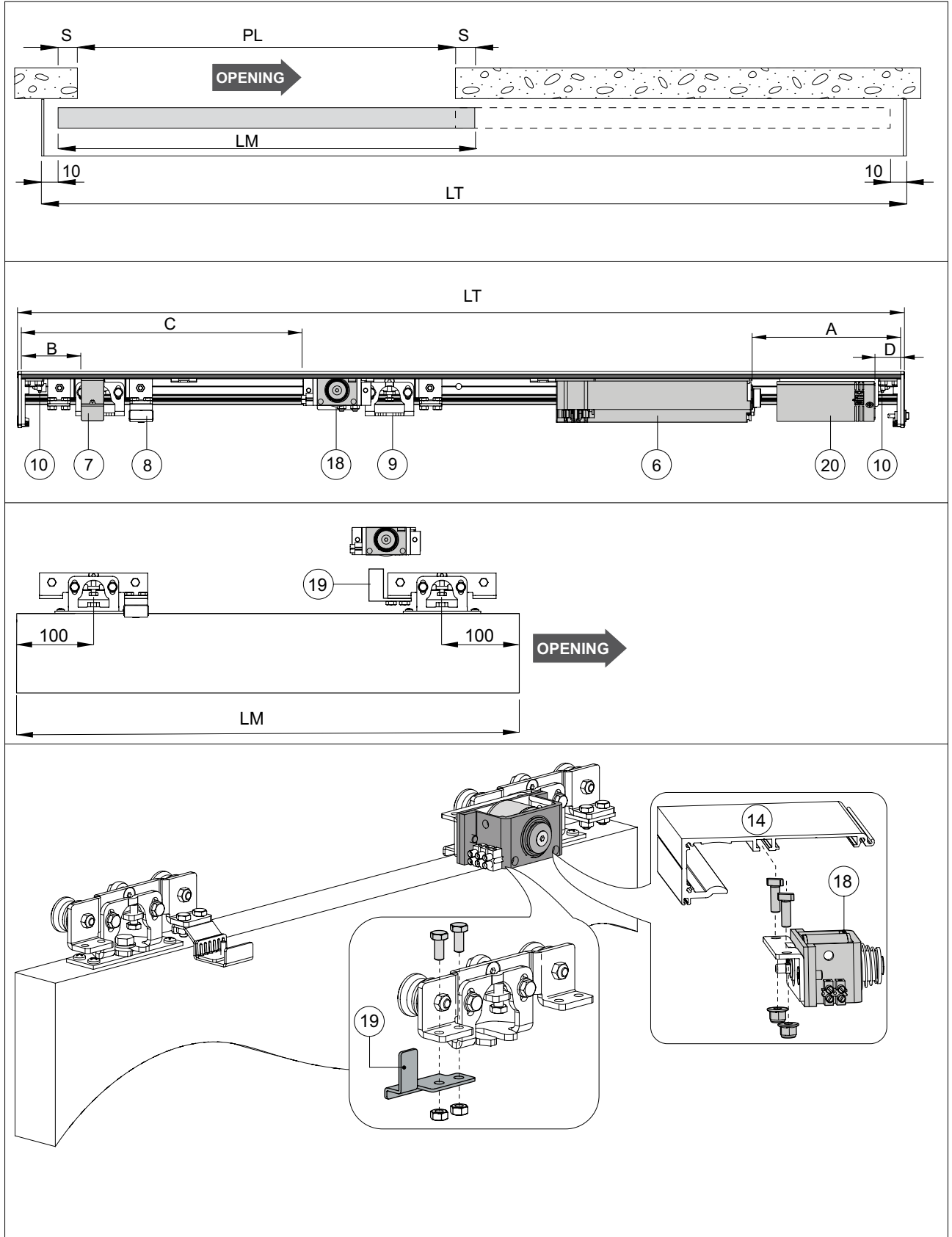

# CIVIK 1 SX

CODE	LT PL + LM + 20 + S	LM	PL	A	B	C	D
DOITCVK16	1650	PL + 2S	LT - LM - 20 - S	250	70	800	80
DOITCVK22	2200			500	70	1050	350
DOITCVK33	3300			1000	70	1600	900

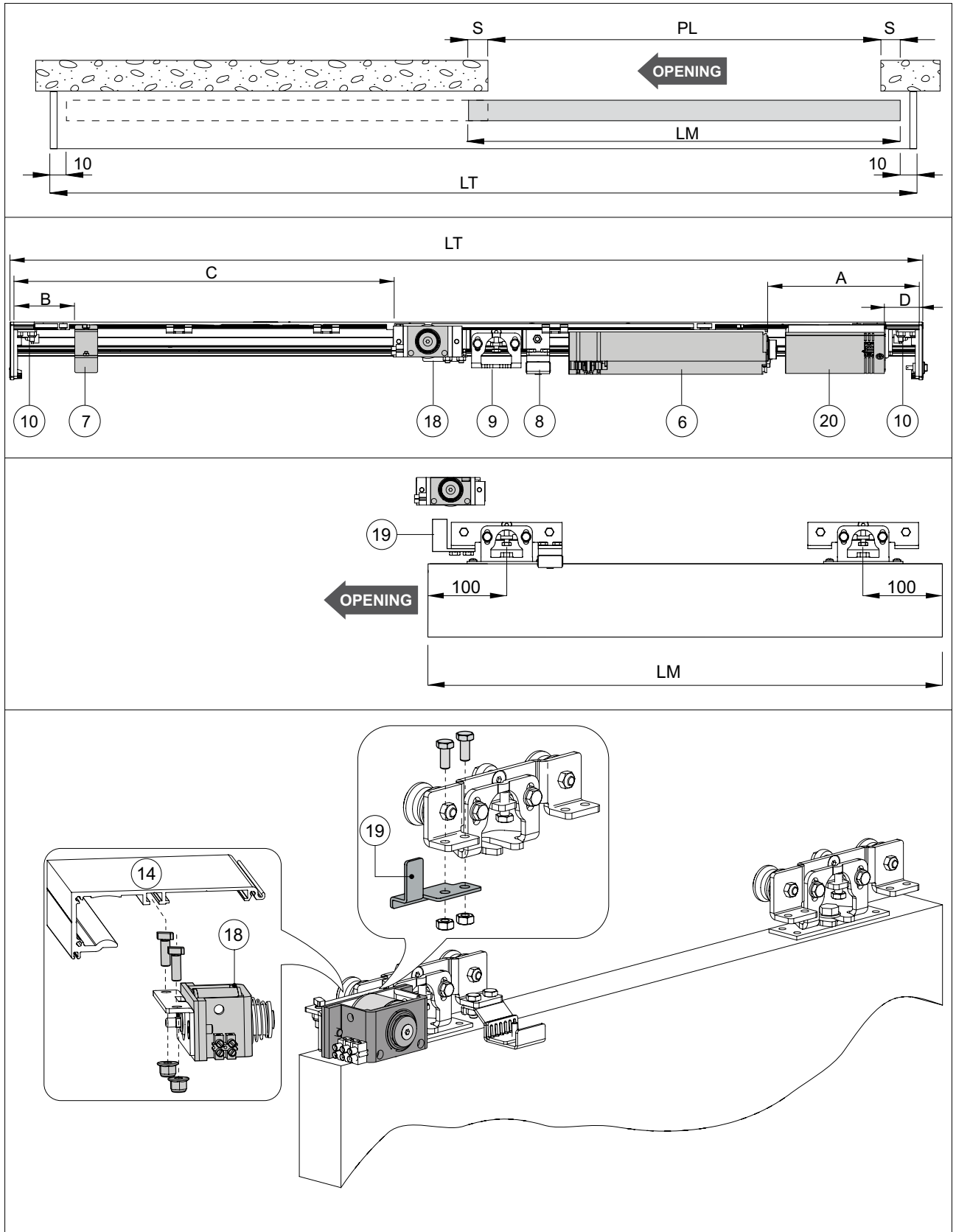

## 5.2 Belt assembling procedure

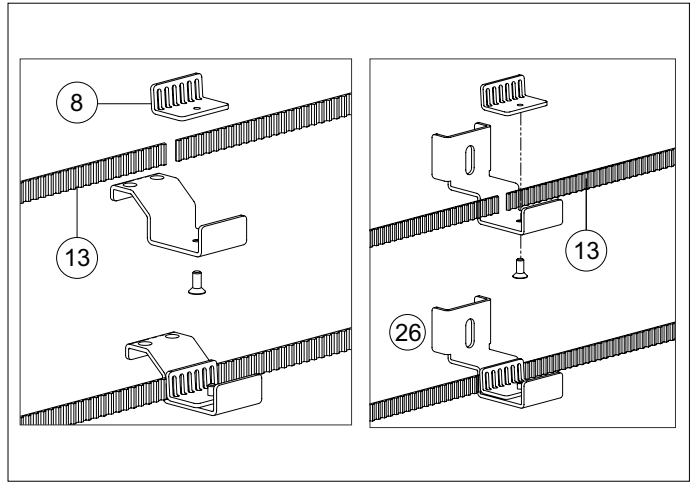
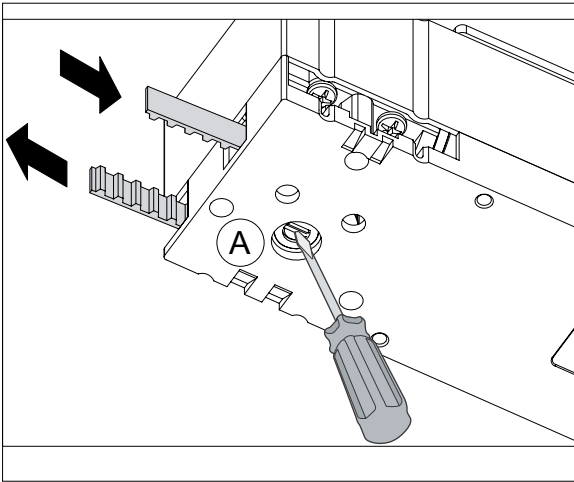

- Insert the belt in the motor, rotating the pin [A] as indicated in the figure.
- Join the belt in line with the belt attachment bracket, as indicated in the figure (on the right of the belt attachment pulling unit [26]). Cut any excess.
- Tighten the belt correctly, moving the belt transmission [7] to the left.
- Tighten all screws and secure the heads to the box.

## 6. INSTALLATION

### 6.1 Housing fastening

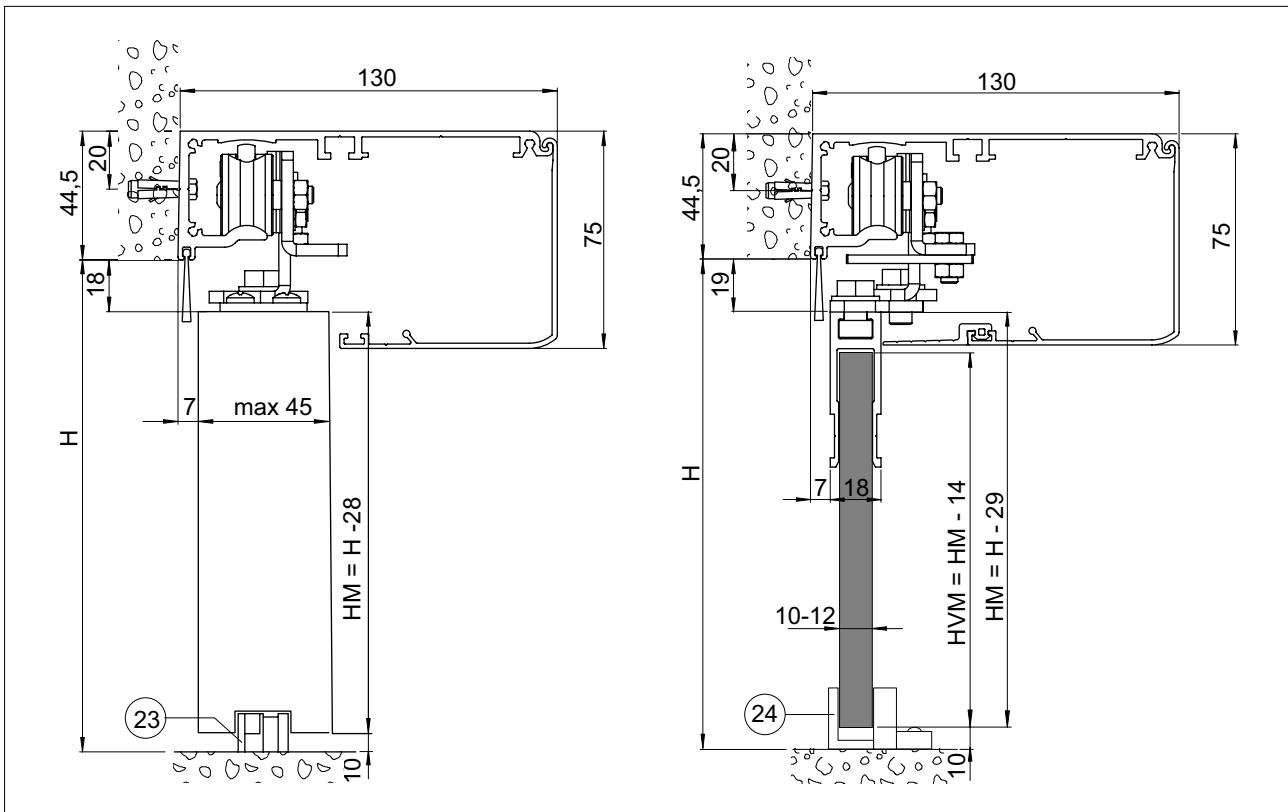

Unless otherwise specified, all measurements are expressed in millimetres (mm).

Figures show the fastening of the housing in accordance with the height of the wing:

- Fasten the housing by means of steel blocks M6 Ø12 or screws 6MA (not provided by us).
- Verify if housing rear side is perpendicular to the floor and not lengthwise deformed by the shape of wall. Should the wall not be straight and smooth, iron plates shall be arranged on it prior to guide fastening.



**WARNING:** the housing must be attached securely to the wall to support the weight of the wings.

## 6.2 Wood door wing preparation

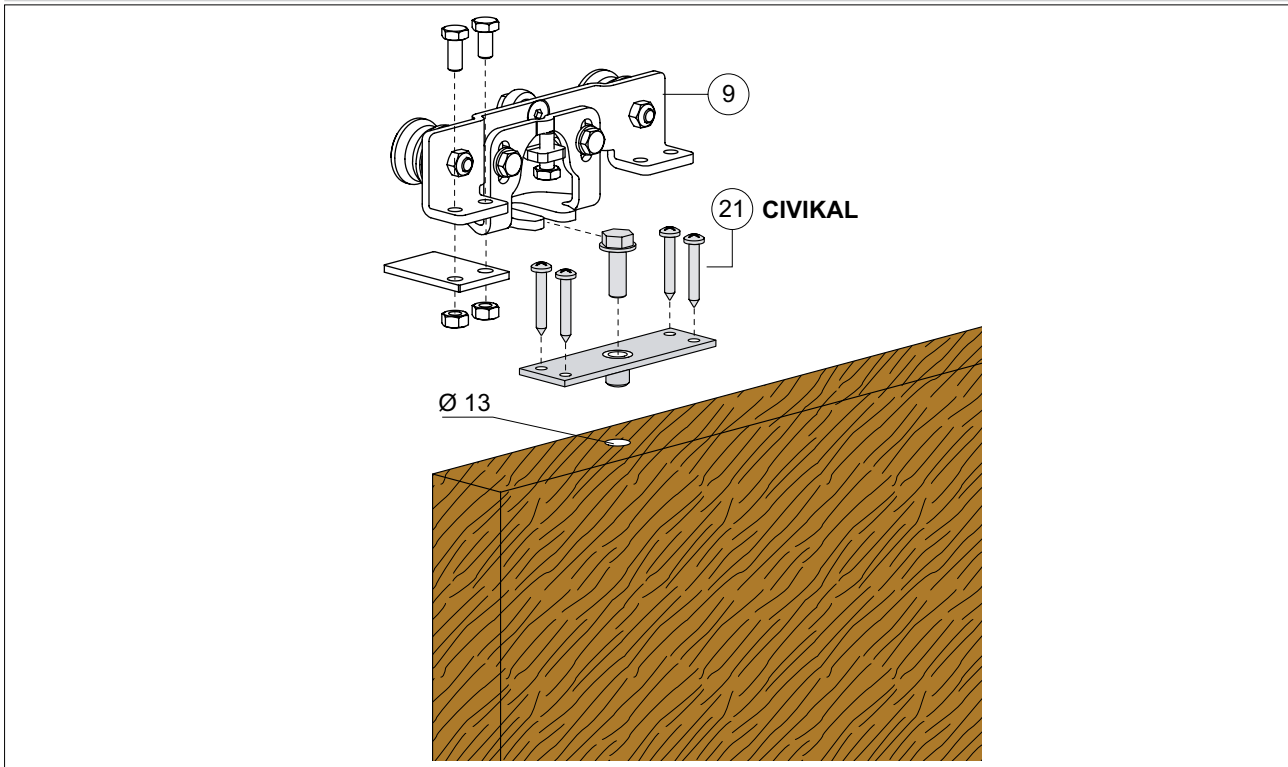

The door must be robustly constructed.

Fix the door wing attachment bracket on the door wing, and fix the latter to the carriage, as indicated in figure. It is advisable to install rubber borders at the ends of the wing to reduce force of impact.

### 6.3 Glass door wing preparation

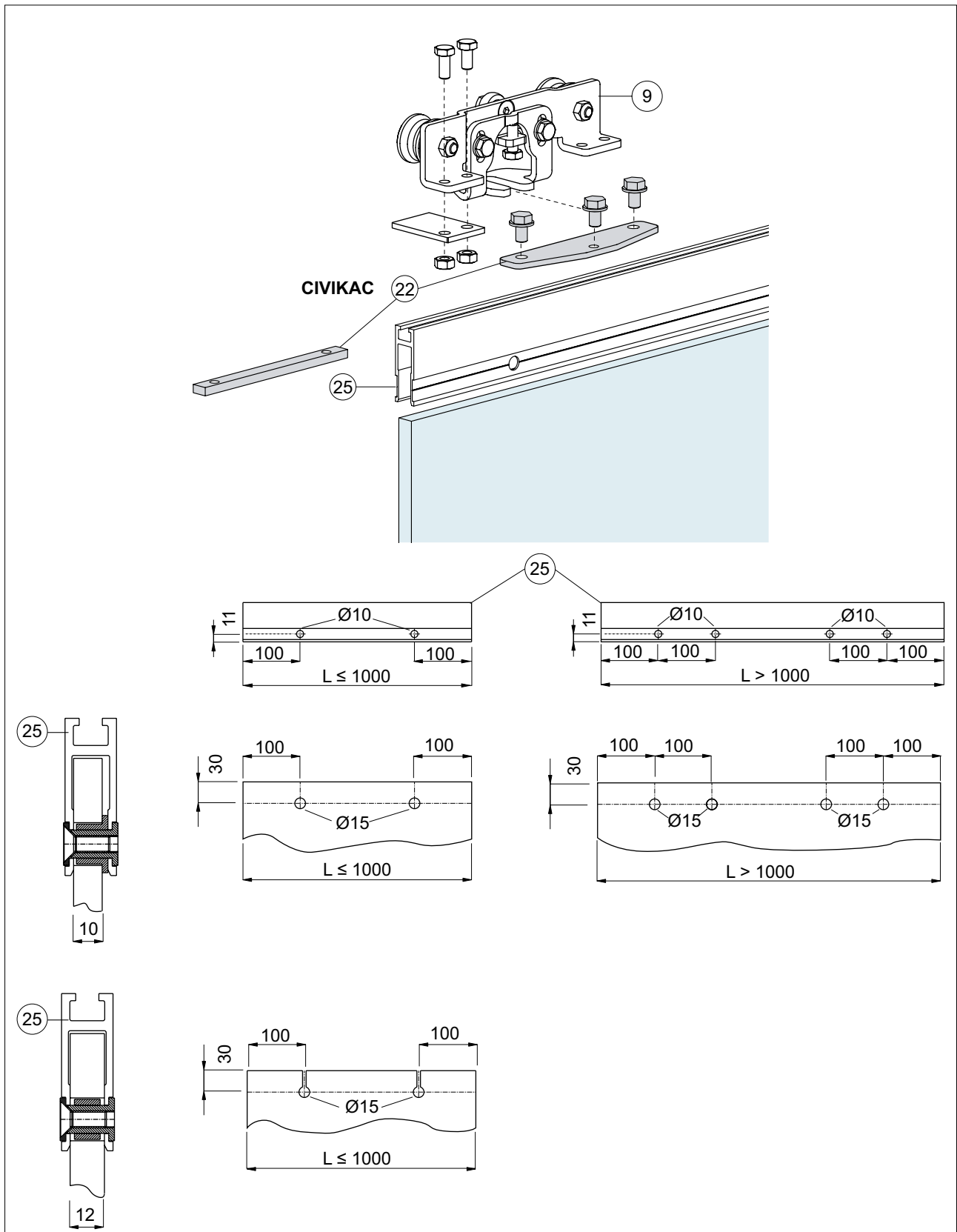

The glass fitting section may be used with glass-only wings of 10 or 12 mm thickness. It is not usable on any kind of normal or stratified glass.

Carry out the operations indicated in figure.

We recommend to apply a light layer of silicone between the glass corner and the end of the profile.



**WARNING:** in closing position for all-glass wings, without gaskets, leave at least 10 mm to avoid contact between glass wings.

## 6.4 Door wing adjustment

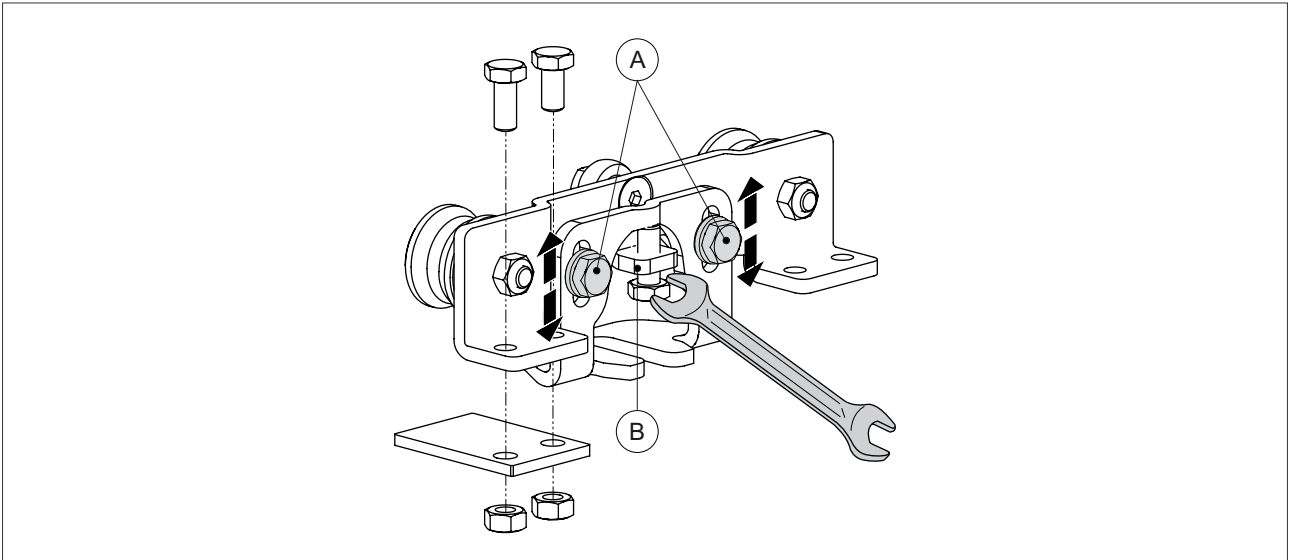

It is possible to adjust the vertical position of the door wing, as shown in the figure.

Loosen the screws [A] and adjust height with screw [B].

Check, by moving the wing by hand, that it moves freely and without friction and that all the wheels bear on the guide.

## 6.5 Belt tightness

- Tighten the belt correctly, moving the belt transmission [7] to the left.



**WARNING:** a wrong adjustment can prevent the automation from working properly.

## 6.6 Guides at floor installation

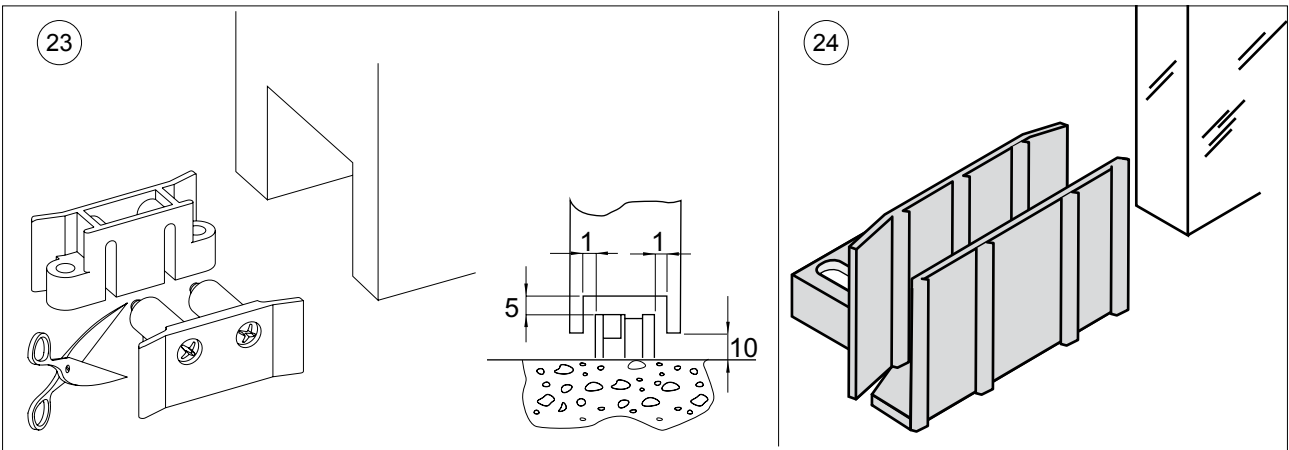

For guides at floor use only antifriction materials such as PVC, NYLON, TEFLON. It is preferable that the length of the guide should not be greater than the overlap between the mobile and fixed wing, and that it not enter the passage space.

The guide slide on the floor must be smooth for the entire length of the wing.

[23] Guide for framed door supplied by us: cut to required.

[24] Guide for glass door supplied by us.

## **6.7 Fastening door wing locking device CIVIKLA**

The door wing locking device can be fitted to keep the door closed. The automation automatically recognises the locking device and acts properly.

- Fix the door wing locking device [18] inside the box, using the screws supplied on the basis of the type of automation chosen.
- Place the door wing in the closure position.
- Fix the lock hook-up bracket [19] to the carriage, as indicated on page 8, 9 and 10.
- Check that, with the door closed, the lock is resting correctly on the lock hook-up bracket, preventing the door from sliding.
- Make the electrical connections as shown in chapter 9.

## **6.8 Fastening of the radio receiver OCL**

It is possible to install the radio receiver that allows the door to be activated by means of wireless commands.

- Fasten the radio receiver [20] inside the box by means of the supplied screws.
- Carry out the electrical connections as shown in the related manual.
- Memorise the transmitters as shown in the related manual.

## **6.9 Installation of COMGC functions selector switch**

The radio selector which allows you to select door functions can be installed using wireless commands:

- Fasten the COMGCR receiver [28] inside the box using the supplied screws.
- Carry out the electrical connections as described in the relevant manual.
- Memorise the COMGTC transmitter [2] as described in the relevant manual.



## 7. INSTALLATION ON DISAPPEARING DOORS

It is possible to install the CIVIK automation on disappearing doors, following the indications of page 18 and 19.

By means of the pulling unit [26], the door wing is connected to the automation belt.

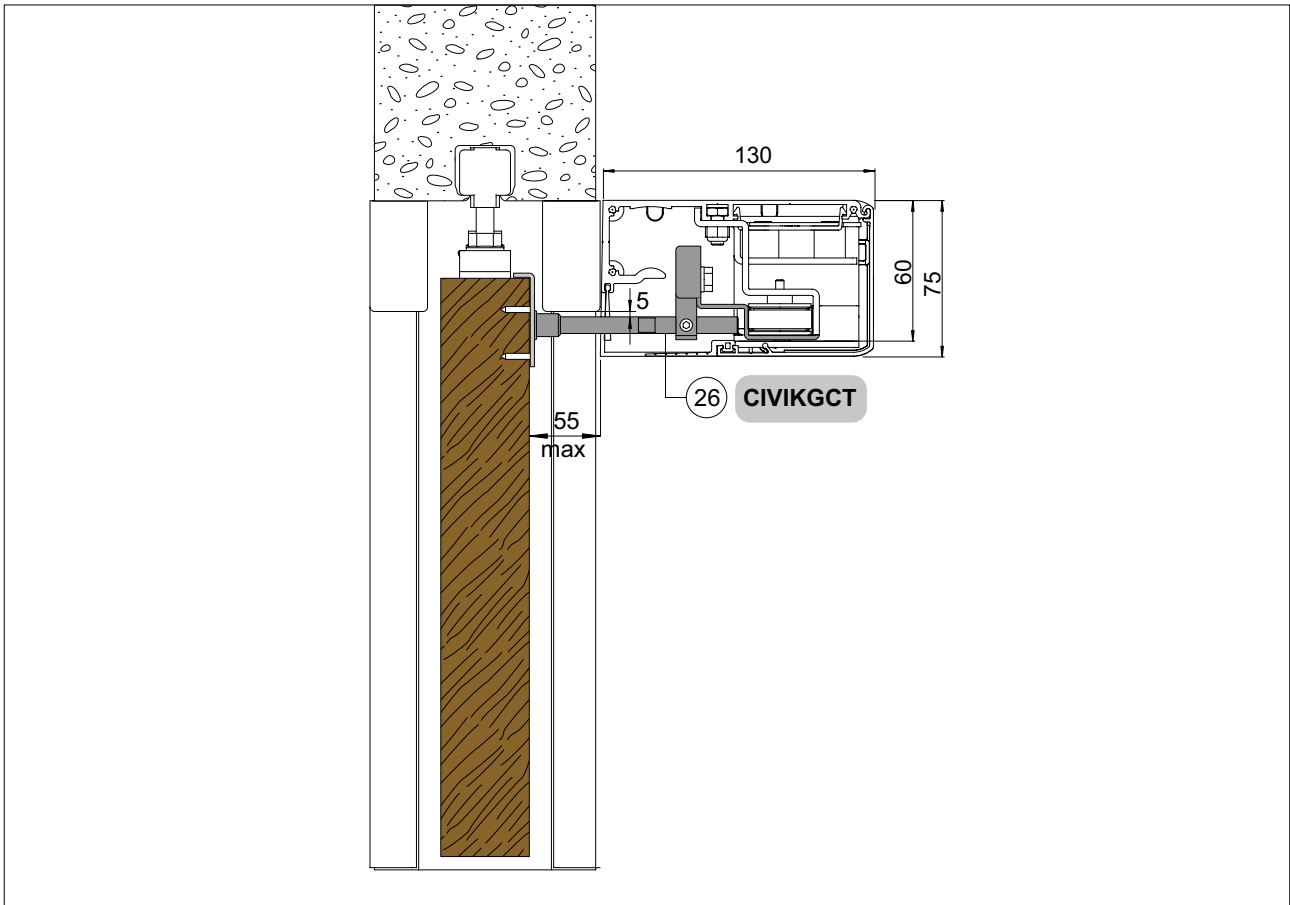

REF.	CODE	DESCRIPTION
26	CIVIKGCT	Second door wing pulling unit
6	KCIVIK1T	Control and drive unit
7		Belt transmission unit
26		Belt attachment bracket - Pulling unit
10		Rabbed lock
11		Wire bracket
12		Housing heads

# DOITCVK2T22

LT	LM	PL	A	B	C	D
2200	$(PL + 2S) / 2$	1500 max	70	300	1000	20

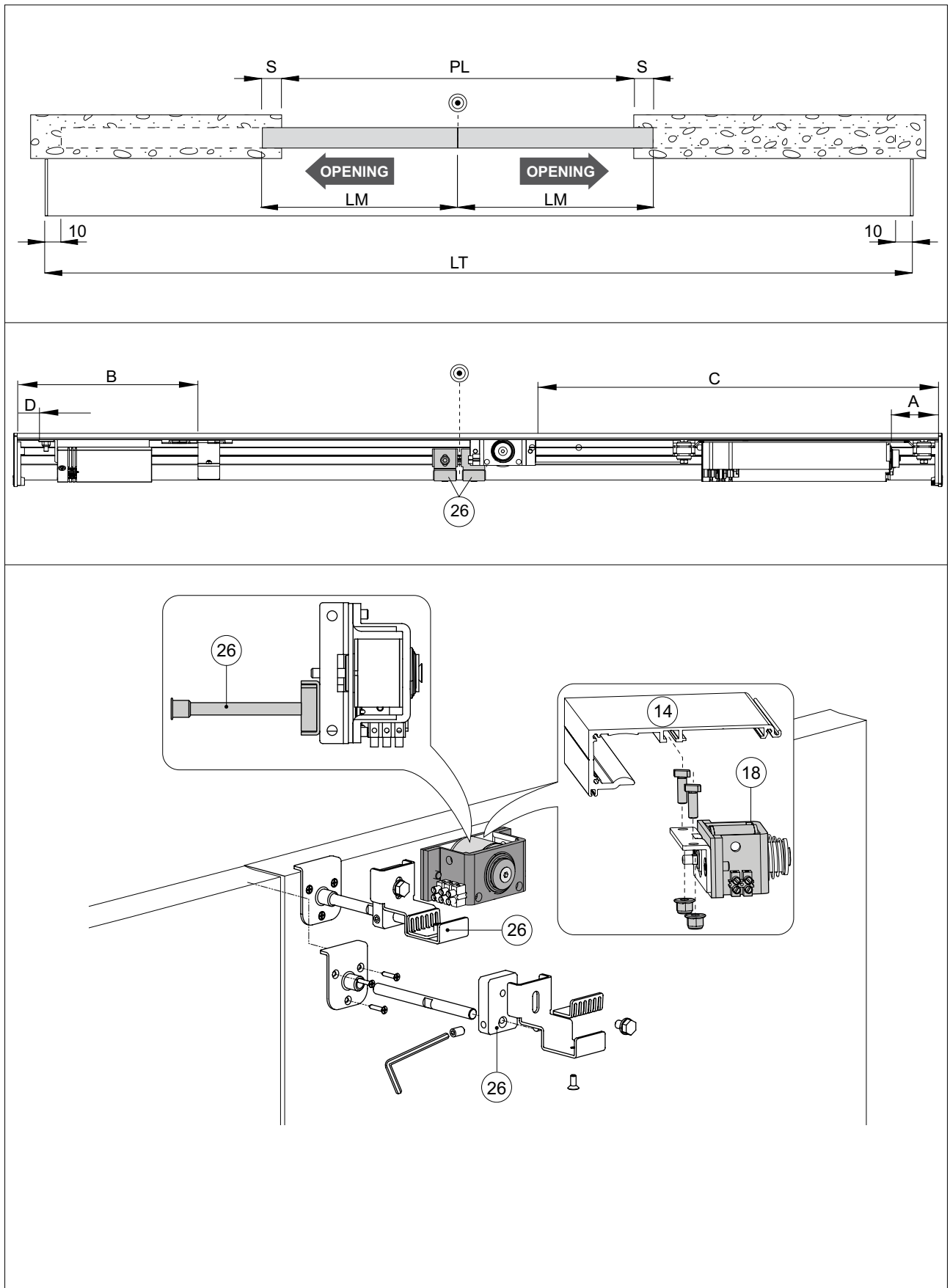

# DOITCVK1T16

LT	LM	PL	A	B	C	D
1600	PL + 2S	1000 max	240	20	80	20

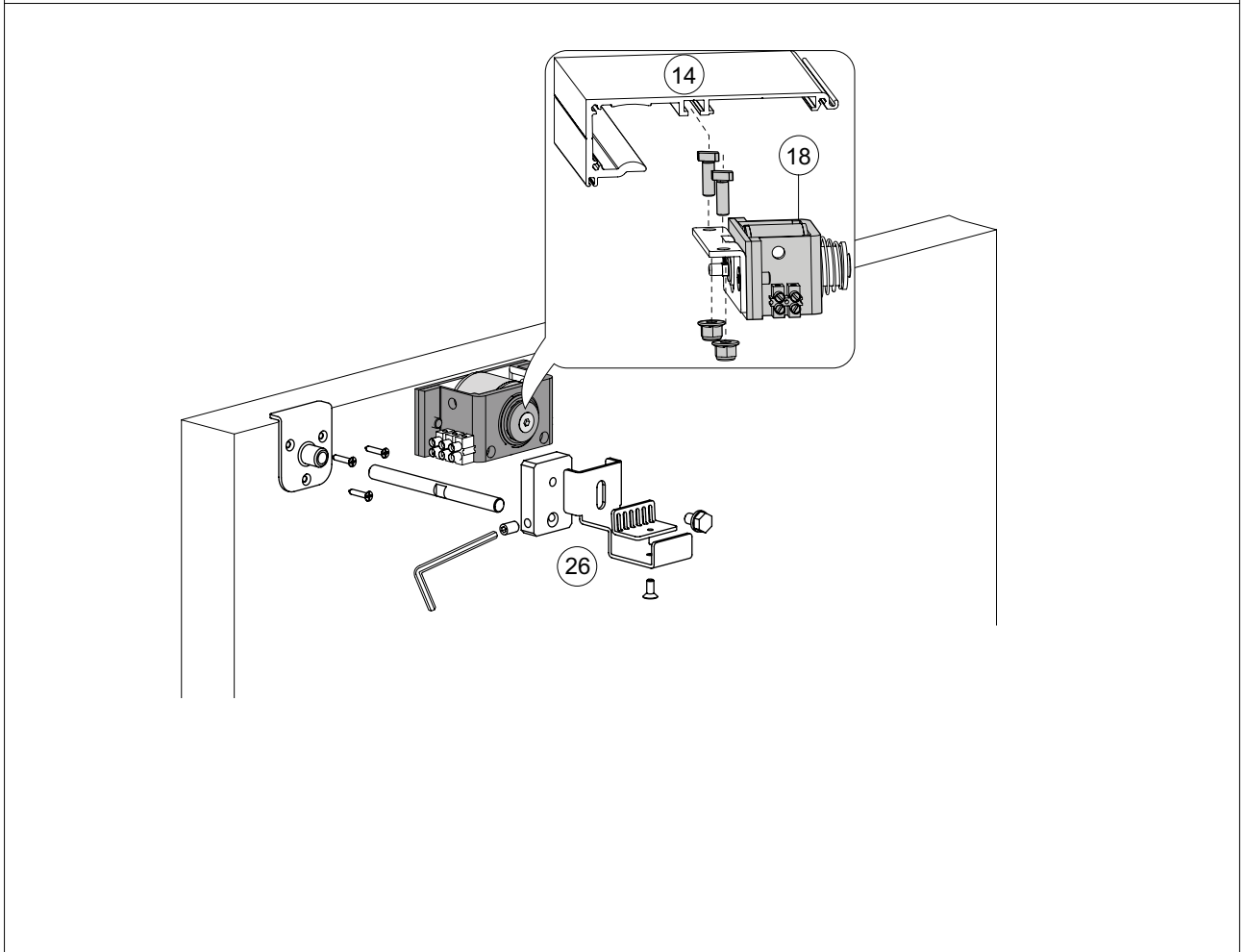
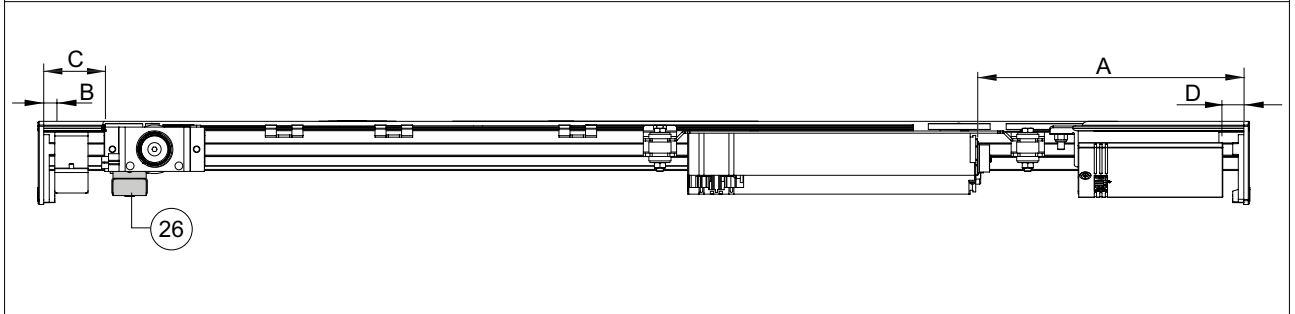
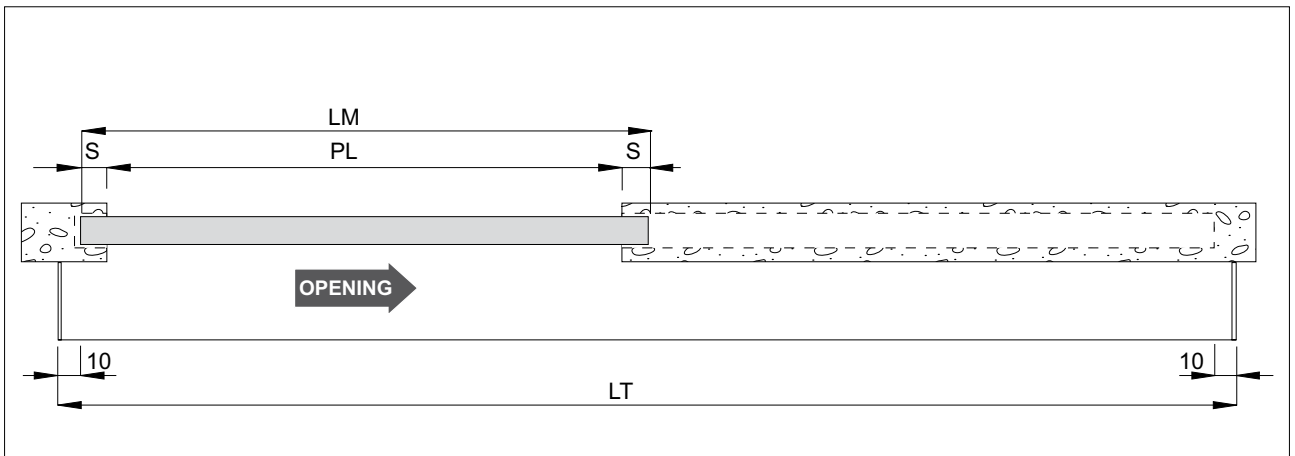

## 8. DOITCV16 - DOITCV22 - DOITCV33 GLASS DOOR WING ATTACHMENT

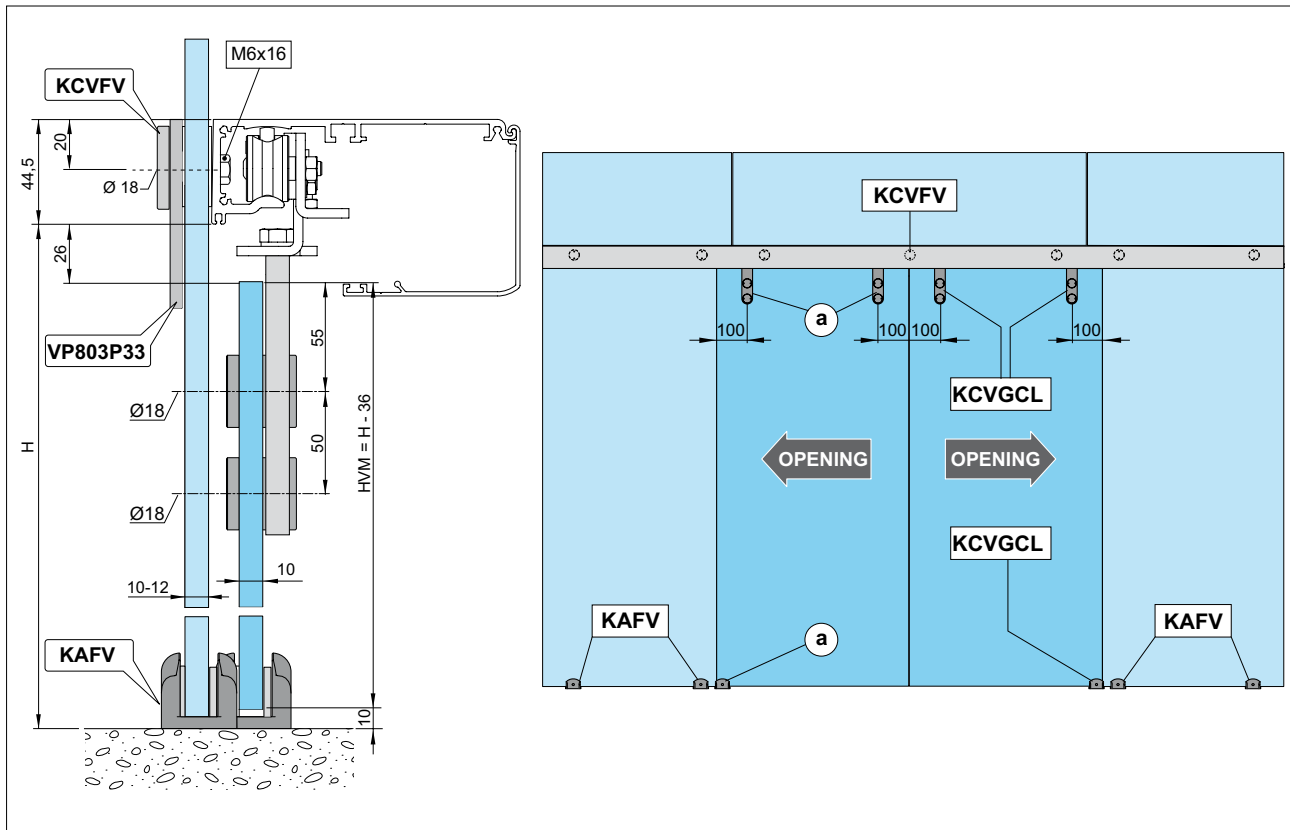

Figure shows the installation measurements for a CIVIK automation made with glass door wings and fixed on glass walls.

The automation casing is supplied with SALLOX STAINLESS STEEL S surface finish (see DITEC colour sample book code X139).

### 8.1 Fastening the box

The CIVIK automation can be fastened directly onto the glass, using the KCVFV fastening kit and the VP803P33 aluminium plate with SALLOX STAINLESS STEEL S finish.

It is also possible to fasten the glass walls to the floor, using the KAFV fastening kit.

**WARNING:** only glass with a thickness of 10-12 mm (not supplied by us) must be used.

The glass should be drilled at least 50 mm from its edge.

### 8.2 Preparing the glass door wing

Use only glass with a thickness of 10 mm (not supplied by us).

To create an automation with two moving door wings, use the KCVGCL kit for the second moving door wing.

**WARNING:** in closing position for all-glass door wings, without gaskets, leave at least 10 mm to avoid contact between glass door wings.

### 8.3 Installing the floor guide

Fasten the guide to the floor, as shown in figure.

The length of the floor guide should not be greater than the overlap between the fixed and mobile door wings, and must not enter the passage space.

## 9. ELECTRICAL CONNECTIONS

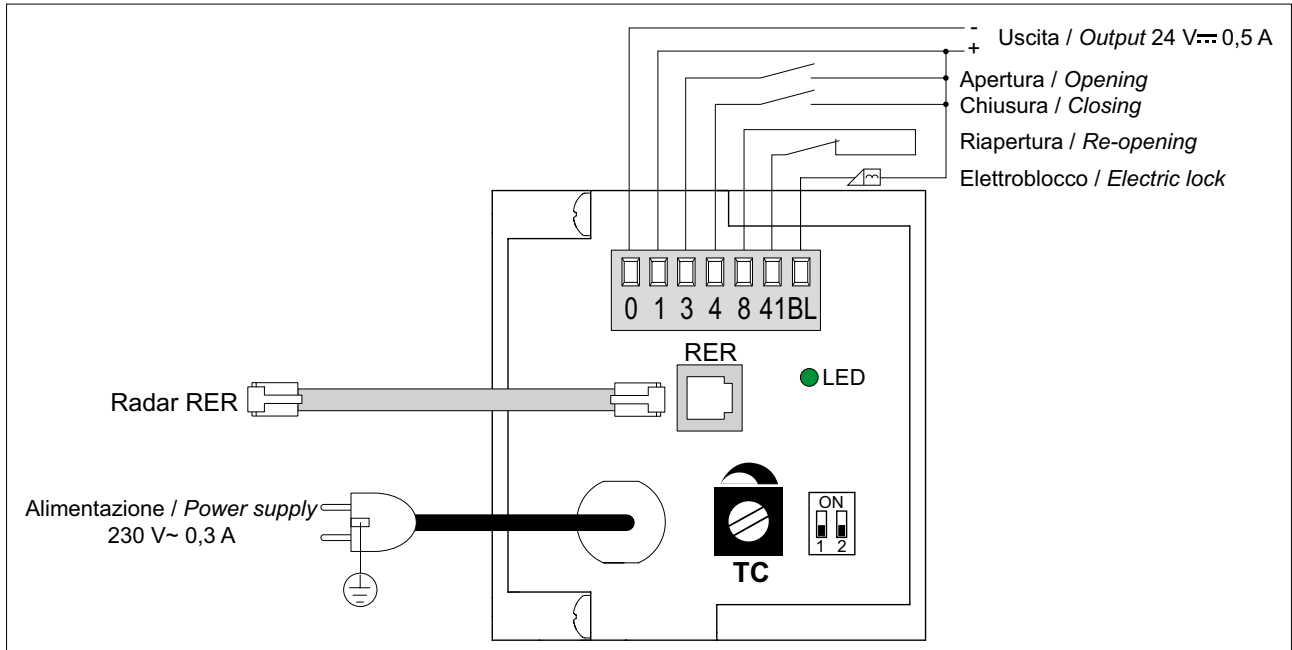



### 9.1 Commands

Command	Function	Description
1 — 3 N.O.	OPENING	The opening manoeuvre starts when the contact is closed.
1 — 4 N.O.	CLOSING	The closing manoeuvre starts when the contact is closed.
1 — 3 1 — 4 N.O.	STOP	The coincidence of an opening and closing command stops all movements. <i>WARNING: when the contact opens again the door proceeds with the interrupted manoeuvre.</i>
41 — 8 N.C.	REVERSAL SAFETY	The opening of the contact during the closure manoeuvre causes the movement to invert (re-opening).

### 9.2 Output and accessories

Output	Value - Accessories	Description
	24 V= 0,3 A	<b>Accessories power supply.</b> Power supply output for external accessories.
	<b>CIVIKLA</b> 24 V= 0,5 A	<b>Lock device.</b> Lock is only activated when the door is closed. <i>NOTE: the door is released in the event of power failure and can be manually operated.</i>

## 9.3 Adjustment

	Description	OFF 	ON 
DIP1	<b>Closure thrust.</b> Maintain the door wing in the closure position.	Disable.	Enable.
DIP2	<b>Direction selection.</b> The opening direction is intended by viewing the automation from the side being examined.	Right-hand opening. Selection for double door wing automations.	Left-hand opening.

<b>TC</b>  	<b>Automatic closing time.</b> From 0 to 30 s. Adjust the time that passes between the end of the opening manoeuvre and the start of the automatic closing manoeuvre. The count is reset when an opening command is given with the door open. Adjust the TC to the maximum if automatic closing is not required.
--	---

LED (bicolor)	On	Flashing
Green	24 V= power supply.	Encoder/automation fault.
Red	Safety contact 41 - 8 open.	Safety test failure.

## 10. STARTING

- Select the desired opening direction with DIP2.
- If required, activate the closure thrust by setting DIP1=ON.
- Set TC to the maximum.
- Turn on the power.

**WARNING:** the control panel performs an automatic RESET on each start (or change of DIP2) and the first opening or closing manoeuvre is performed at low speed allowing the automatic self-learning of the stop positions (acquisition).

- Check that the door is operating correctly with subsequent opening and closing commands.
- If required, set the automatic closing with the TC.
- Connect possible accessories and check they are functioning.

**WARNING:** if the RER radar is used, set the radar dip-switch RER=DX.

- If the automation encounters an obstacle during closure, it is detected and the automation opens again. If the automation encounters an obstacle during opening, it is detected and the automation stops. If the obstacle is detected twice in a row, it is considered as the new stop until it is removed.
- The automation is equipped with the Push&Go function. The motorised opening or closing operation is activated when the door is pushed.

## 11. ROUTINE MAINTENANCE PLAN

Perform the following operations and checks every 6 months according to intensity of use of the automation.

Turn off the power.

- Clean the moving parts (the carriage guides).
- Check the belt tension.
- Clean sensors and photocells (if present).
- Check the stability of the automatic system and make sure that all screws are correctly tightened.
- Check the alignment of the door wing and the stop position.

Turn on the power.

- Check the stability of the door and that the movement is regular and without friction.
- Check that all command functions are operating correctly.
- Check that the photocells are operating correctly (if present).
- Check that the door's developed powers are in accordance with the present standards.



**NOTE:** for spare parts, see the spares price list.



TEAR OFF AND DELIVER TO USER

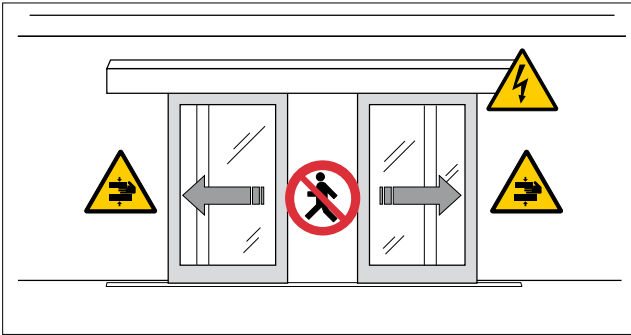

### 12.1 General safety precautions

The following precautions are an integral and essential part of the product and must be supplied to the user. Read them carefully since they contain important information on safe installation, use and maintenance. These instructions must be kept and forwarded to all possible future users of the system.

This product must only be used for the specific purpose for which it was designed.

Any other use is to be considered improper and therefore dangerous.

The manufacturer cannot be held responsible for any damage caused by improper, incorrect or unreasonable use.

Avoid operating in the proximity of the hinges or moving mechanical parts.

Do not enter within the operating range of the motorized door while it is moving.

Do not block the movement of the motorized door since this may be dangerous.

Do not allow children to play or stay within the operating range of the motorized door.

Keep remote controls and/or any other control devices out of the reach of children in order to avoid possible involuntary activation of the motorized door.

In the event of fault or malfunctioning of the product, turn off the power supply switch, do not attempt to repair or intervene directly and contact only professionally competent personnel.

Failure to comply with the above may cause a dangerous situation.

All cleaning, maintenance or repair work must be carried out by professionally competent personnel.

To ensure that the system works efficiently and correctly, the manufacturer's indications must be complied with and routine maintenance of the motorized door must be performed by professionally competent personnel.

In particular, regular checks are recommended in order to verify that the safety devices are operating correctly.

All installation, maintenance and repair work must be documented and made available to the user.

 For the correct disposal of electric and electronic equipment, waste batteries and accumulators, the user must take such products to the designated municipal collection facilities.

### 12.2 Manual release instructions

In the event of malfunction or if there is no mains power supply, move the door manually.

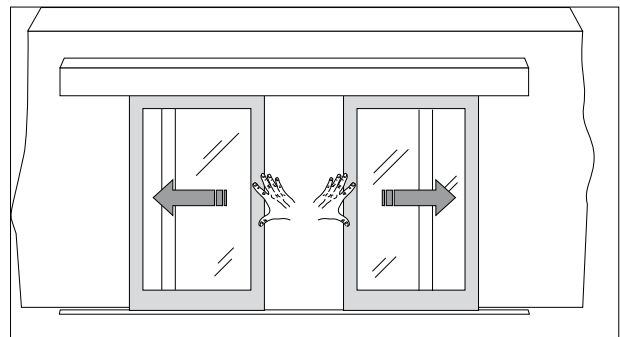

Installer:

Empty rounded rectangular box for installer signature.



**DITEC S.p.A.**  
Via Mons. Banfi, 3  
21042 Caronno Pertusella (VA) - ITALY  
Tel. +39 02 963911 - Fax +39 02 9650314  
www.ditec.it - ditec@ditecva.com

**ENTREMATI**



**DITEC S.p.A.** Via Mons. Banfi, 3 21042 Caronno P.Ia (VA) Italy Tel. +39 02 963911 Fax +39 02 9650314  
[www.ditec.it](http://www.ditec.it) [ditec@ditecva.com](mailto:ditec@ditecva.com)

**DITEC BELGIUM** LOKEREN Tel. +32 9 3560051 Fax +32 9 3560052 [www.ditecbelgium.be](http://www.ditecbelgium.be) **DITEC DEUTSCHLAND** OBERURSEL  
Tel. +49 6171 914150 Fax +49 6171 9141555 [www.ditec-germany.de](http://www.ditec-germany.de) **DITEC ESPAÑA** ARENYS DE MAR Tel. +34 937958399  
Fax +34 937959026 [www.ditecespana.com](http://www.ditecespana.com) **DITEC FRANCE** MASSY Tel. +33 1 64532860 Fax +33 1 64532861 [www.ditecfrance.com](http://www.ditecfrance.com)  
**DITEC GOLD PORTA** ERMESINDE-PORTUGAL Tel. +351 22 9773520 Fax +351 22 9773528/38 [www.goldporta.com](http://www.goldporta.com) **DITEC SVIZZERA**  
BALERNA Tel. +41 848 558855 Fax +41 91 6466127 [www.ditecswiss.ch](http://www.ditecswiss.ch) **DITEC ENTREMATIC NORDIC** LANDSKRONA-SWEDEN  
Tel. +46 418 514 50 Fax +46 418 511 63 [www.ditecentrematicnordic.com](http://www.ditecentrematicnordic.com) **DITEC TURCHIA** ISTANBUL Tel. +90 21 28757850  
Fax +90 21 28757798 [www.ditec.com.tr](http://www.ditec.com.tr) **DITEC AMERICA** ORLANDO-FLORIDA-USA Tel. +1 407 8880699 Fax +1 407 8882237  
[www.ditecamerica.com](http://www.ditecamerica.com) **DITEC CHINA** SHANGHAI Tel. +86 21 62363861/2 Fax +86 21 62363863 [www.ditec.cn](http://www.ditec.cn)